

ZEROAVIA

The Future of Zero-Emission,
Hydrogen-Electric Flight



ZeroAvia is developing the first practical zero-emission powertrain for commercial aviation, with a vision for hydrogen-electric engines in every aircraft, delivering true zero-emission flight.

We are market leaders in developing this vital approach, having demonstrated the technology in six-seat and 19-seat airframes, with a clear pathway to certification for the latter.

ZeroAvia is planning to supply airlines, lessors and OEM partners with hydrogen-electric engines, while supporting operators and airports with access to low-carbon hydrogen fuel.

We will enable the transition to zero-emission operations for many in the industry well within this decade. We are focused initially on offering hydrogen-electric propulsion systems and airport infrastructure systems.

Powertrain Timeline



Our Mission

ZeroAvia's mission is a hydrogen-electric engine in every aircraft. We have concluded that combining fuel cell power generation with electric propulsion systems is the long-term answer for all segments of commercial aviation, offering truly clean propulsion and lower operating costs.

ZeroAvia is first targeting retrofit of its hydrogen-electric engines with existing fixed-wing and rotorcraft airframes to reduce time to market, while also partnering with clean-sheet designers. ZeroAvia plans for certification of its ZA600, 600kW 9-19 seat engine as early as 2025, before certifying the ZA2000 engine for up to 80 seat regional turboprops by 2027.

ZeroAvia is using the Dornier 228 aircraft to flight test its 600kW hydrogen-electric powertrain



In a study published in June 2020, Clean Sky, the largest European research programme, estimates that direct burn hydrogen systems can reduce the global warming effect of flying by between 50 and 75 per cent, and Sustainable Aviation Fuels (SAFs) can reduce it by between 30 and 60 per cent. The study's authors believe that the fuel cell has the potential to reduce climate impact by 75 to 90 per cent. Our estimates based on the latest technology put this even higher at around 95 per cent.

As one of the hardest to abate sectors, aviation is predicted to account for in excess of 25% of Greenhouse Gases (GHG) emissions by 2050 without action taken. Sustainable Aviation Fuels (SAF) are a start, but they cannot be the only solution as they can't remove carbon emissions fully, nor can they tackle non-CO2 emissions like NOx, SOx, particulates, and soot. There are also big challenges in scaling the volume of SAFs.

The answer must be electrification, but batteries' energy-to-weight ratio makes them impractical for commercial flight.

Reduction in Climate Impact

	Direct CO2	Nox	Water Vapor & Contrails	Total	Technology Scalability	Net Impact
H2-Electric	Complete	Complete	Moderate	Moderate	Complete	Complete
Battery Electric	Complete	Complete	Complete	Complete	Limited	Limited
Hybrid-Electric	Moderate	Limited	Limited	Limited	Moderate	Moderate
Sustainable Aviation Fuels (SAF)	Moderate	Limited	Limited	Limited	Moderate	Moderate
H2-Combustion	Complete	Moderate	Limited	Limited	Complete	Moderate

Source: market research analyst reports ● Complete ● Moderate ● Limited

Hydrogen-Electric, Zero-Emission Flight

Hydrogen is the lightest molecule in the universe. As fuel in onboard tanks, it can be used in fuel cells in a chemical reaction to generate the required electricity to drive electric motors, with no emissions besides water. Hydrogen-electric propulsion is plainly the solution to addressing aviation's full climate impact.

Hydrogen-electric makes the most business and technological sense of all sustainable aviation solutions because:

Hydrogen has 15-50 times more energy density than the best electric batteries today and is the most abundant substance in the universe. It can be harnessed via renewable energy sources, making for clean fuel production.

The cost of producing low-carbon hydrogen is already competitive with jet kerosene for some airline operators; it is falling dramatically and will do so exponentially given government interventions already in effect or pending.

Fuel cells are also 2-3 times more efficient systems than combustion engines and, due to the lower temperature reactions, will face less wear and tear, meaning significantly lower operating costs



We are developing hydrogen fuel cell power generation to convert hydrogen into electricity which is then used to power electric motors, which turn propulsors to generate thrust. Our world-leading hydrogen-electric powertrain system consists of six core elements:

Hydrogen Management System (HMS) - including optimized storage using the lightest possible tanks and sensing equipment.

Power Distribution System (PDS) - enabling stable power supply from the hydrogen PGS to the EPS and charging aircraft batteries and electrical systems.

Electric Propulsion System (EPS) - state-of-the-art electric propulsion system to deliver ultra-high torque and unparalleled responsiveness.

Hydrogen Power Generation System (PGS) - a proprietary hydrogen fuel cell system architecture designed and rigorously tested for aviation.

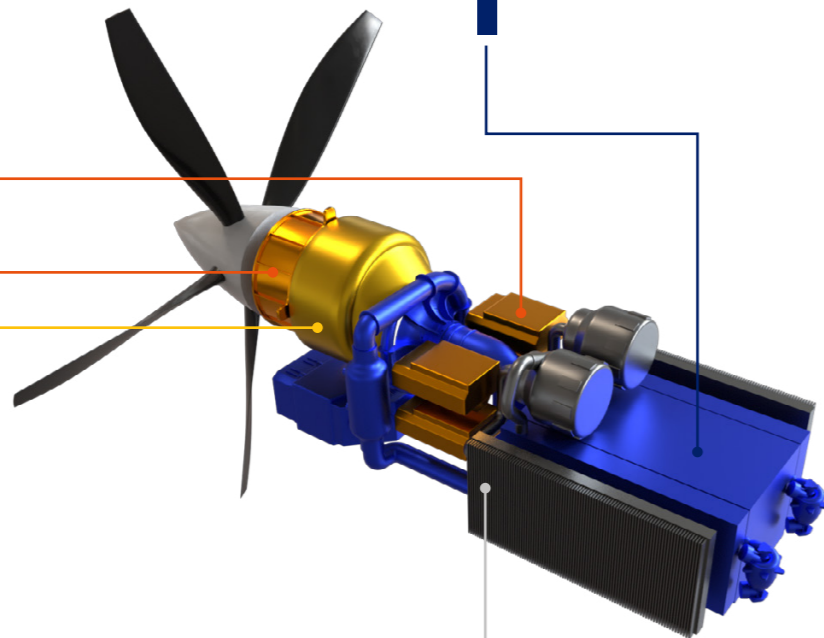

Gearbox - The transmission device by which the aircraft and system accessories, including the PGS compressor, are driven by the main propulsion motor.

Heat Exchangers - Maintain the electric motor, fuel cells and the inverters at their desired operating temperature. Rejects excess heat to the environment.

[Click here to find out more](#)

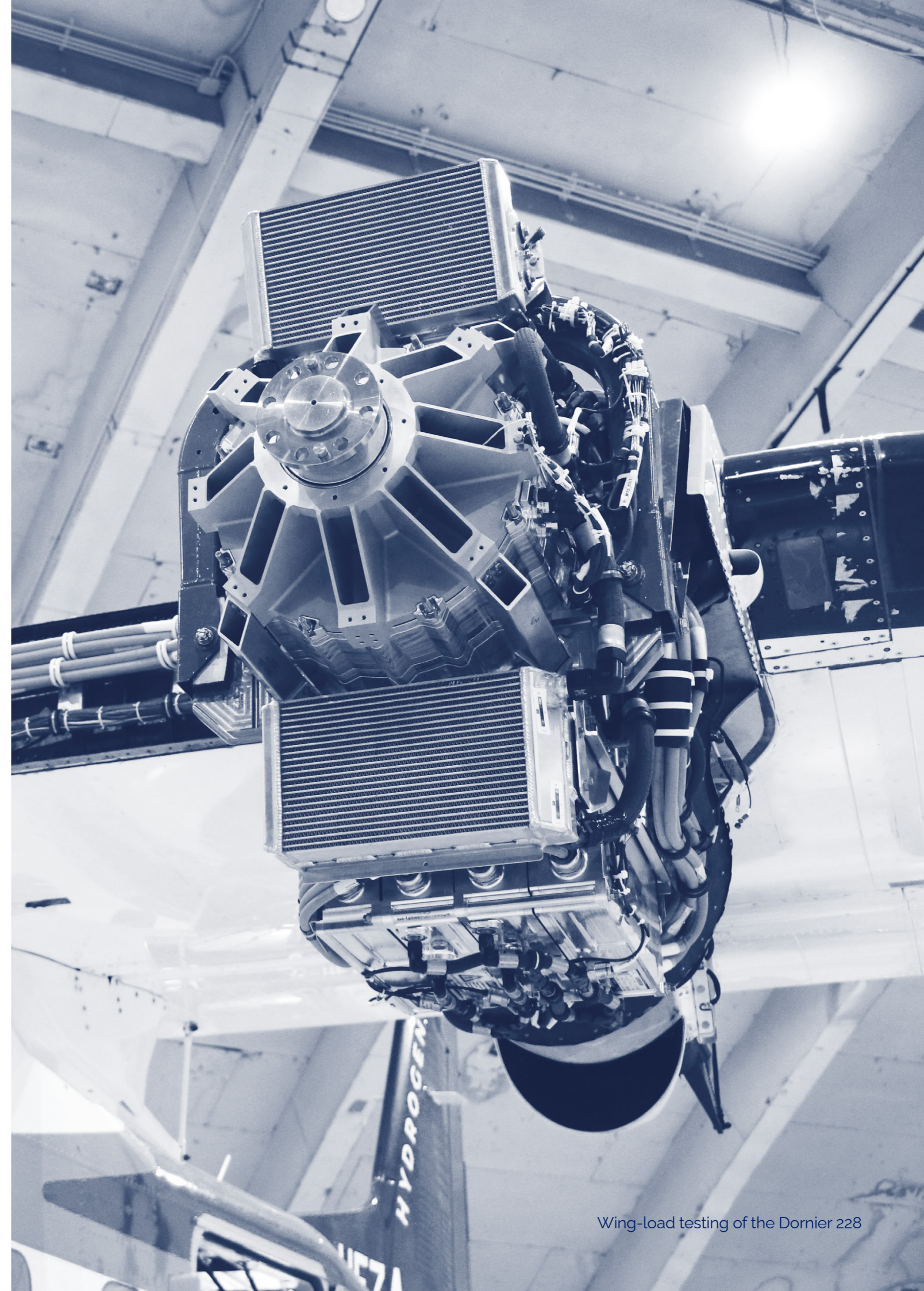

Wing-load testing of the Dornier 228

We are primarily targeting the following airframes but exploring a range of other in-service and in-production airframes.



ZA600 3D render

Our first two powertrains, the ZA600 and ZA2000, will service the regional aviation market, tackling most regional passenger and cargo flight missions to deliver zero-emission flight and cost savings.

These powertrains will be retro-fitted and line-fitted to existing aircraft or incorporated into all new designs.



Engine Class	Power Output	Range	Estimates/ Cargo Payload	Example Airframes
ZA600	600 kW	300+ nm (+ IFR reserve)	9-19 seat	<ul style="list-style-type: none"> • DHC-6 Twin Otter • Dornier 228 • Cessna 208B Grand Caravan
ZA2000	Modular 2.0 - 5.4 MW	500-1,000 nm (+IFR reserve)	40-80 seat	<ul style="list-style-type: none"> • DHC Dash 8 Family • ATR 42/72
ZA2000RJ	Modular 5 - 10 MW	Up to 1000+ nm (+ IFR reserve)	40-90 seat	<ul style="list-style-type: none"> • CRJ series

ZA2000 3D render

ZeroAvia has developed detailed operational plans with first-mover airports to ensure the seamless, cost-effective provision of low-carbon hydrogen fuel at airport sites. Each airport environment has unique needs, and we have identified and modelled three key pathways of delivery to support most use cases:

Full end-to-end generation -

on-site renewable energy to power H2 electrolyzers and enable on-site green hydrogen production, coupled with a refuelling ecosystem of hydrogen pipelines and/or refuelling bowsers



[Click here to find out more](#)

On-site H2 production -

using nearby renewables/low-carbon energy to produce green hydrogen on-site, coupled with a refuelling ecosystem of hydrogen pipelines and/or refuelling bowsers

Centralized H2 production

and storage - road transportation to airport sites, distribution via refuelling ecosystem of hydrogen pipelines and/or refuelling bowsers

H2 means Lower Costs, Stable Prices and Zero-Emissions

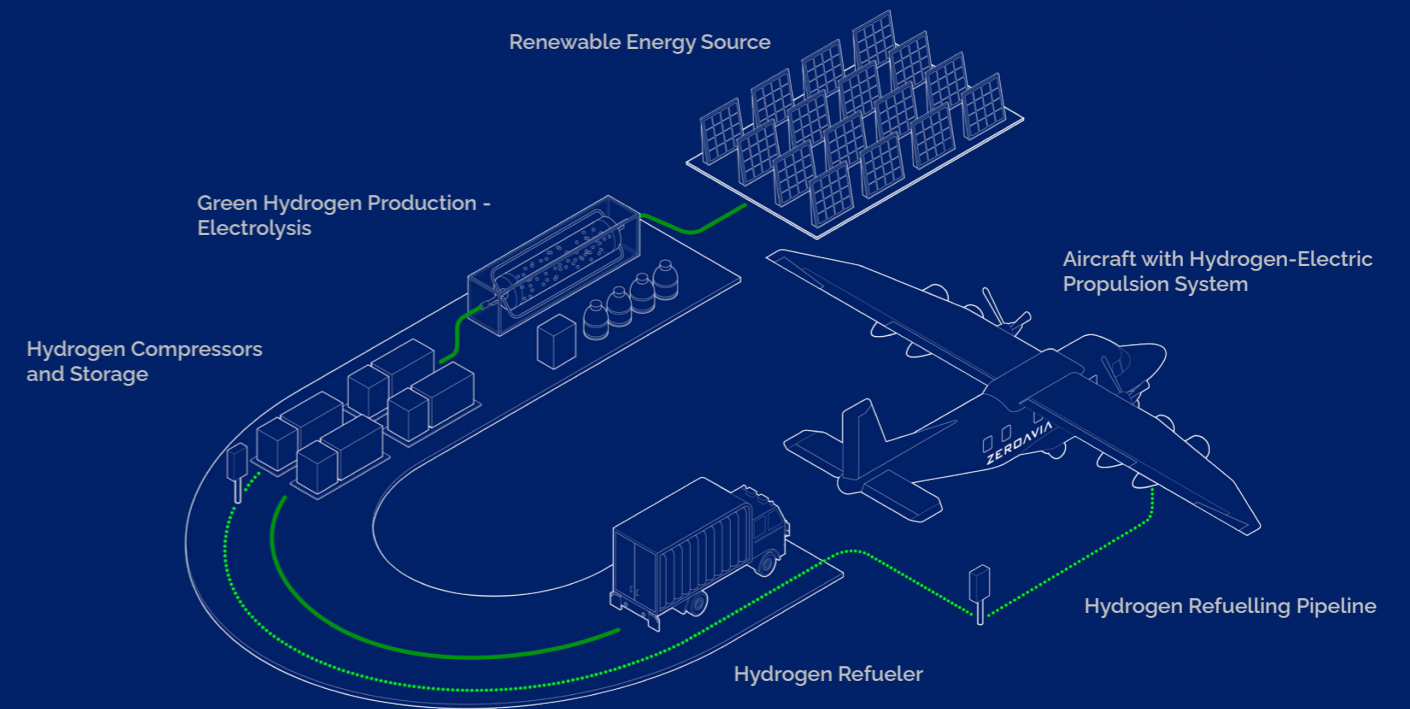

It is a common misconception that hydrogen fuel costs will be a barrier to aviation uptake when it is, in fact, a key selling point in comparison to jet kerosene (and other alternatives). Green hydrogen - which is made using only renewable energy and water - is predicted to be five times lower cost than SAF by 2050. There is significant support both in the US and Europe for hydrogen production from low carbon sources and we expect this and the development of the low carbon hydrogen ecosystem to drive down costs making hydrogen attractive versus jet fuel. We calculate rapidly falling green hydrogen prices with major governments, including the U.S., targeting \$1/kg by the end of the decade. The \$1/kg hydrogen cost target, once achieved, will represent a 75% reduction in spend per gallon of fuel.

ZEROAVIA

Contact us:

info@zeroavia.com

www.zeroavia.com

[Click here to find out more](#)

UK

Hangar C2 Cotswold Airport, Kemble, Cirencester, England, GL7 6BA
The Office Group, 20 Eastbourne Terrace, London W2 6LG

US

90 Skylane Dr, Hangar 1, Hollister, CA 95023
3101 111th St SW, Suite Q, Everett, WA 98204